



[Home](#)
[About Us](#)
[Products](#)
[Accessories](#)
[Customization](#)
[Buy Now!](#)
[Contact Us](#)
[PRODUCTS](#)

## Products: S-Series 110-I



MODEL	LENGTH	WIDTH	HEIGHT	DRAWINGS	
				(.pdf)	(.dwg)
<b>110-I</b>	3.610"	2.270"	1.010"		
<a href="#">Click to view circuit board diagram (310, 410)</a>					

### FEATURES

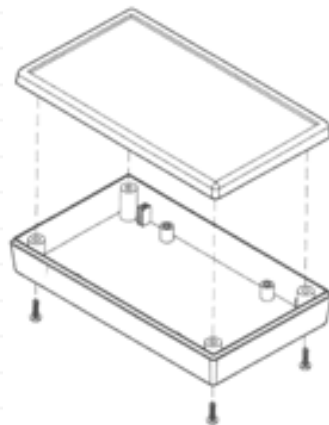

- Two-piece standard design
- -I refers to the "I" version of a model, with a 0.015" smooth depression on top for printing or flush membrane/label surface
- Circuit board mounting bosses
- Assembly with four screws
- Customization available
  - two insert areas/I-Plates ([top and bottom](#))
  - [machining](#)
  - [pad printing](#)

### COLORS



Black



Almond



Gray

[Custom Colors Also Available](#)

[RETURN TO TOP](#)

**ACCESSORIES** (Click an accessory for compatible models and part numbers)

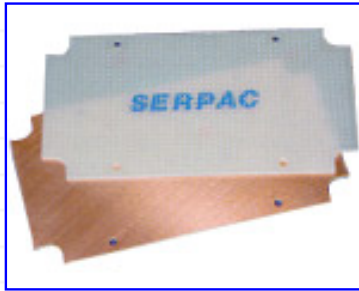

Grid and Clad Prototyping Boards  
(P/N 310, 410)

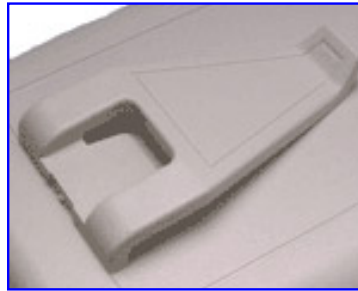

Pocket Clip



Key Holder



Non-Skid Feet (P/N 50)

[RETURN TO TOP](#)

[Home](#) | [About SERPAC](#) | [Products](#) | [Accessories](#) | [Customizations](#) | [Distributors](#) | [Buy Now!](#) | [Contact Us](#)

PRODUCTS: [A-Series](#) | [C-Series](#) | [CA-Series](#) | [CH-Series](#) | [G-Series](#) | [H-Series](#) | [M-Series](#) | [R-Series](#) | [S-Series](#) | [SL-Series](#)

© 2004, SERPAC Electronic Enclosures. All Rights Reserved